

Selection of Screw Jack System and Arrangement

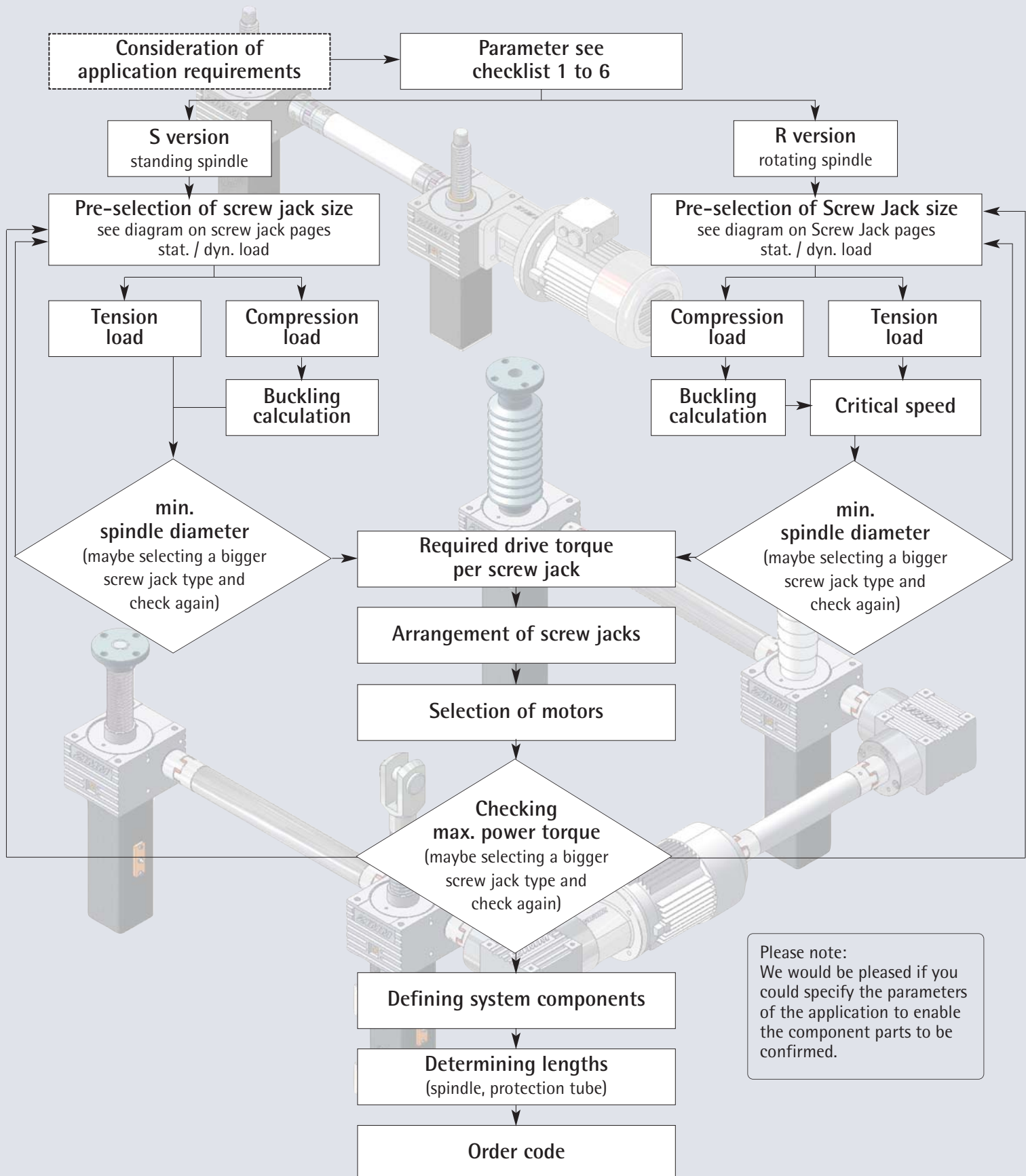

Construction Advice

Design & Specification

The customer, based on the application criteria can determine the selection and dimensioning of the system from the information contained in this catalogue. On request we can provide design advice and calculations to determine the correct components and compile a full quotation based on your application criteria. ZIMM guarantee the quality of all of the components shown in the catalogue. The screw jacks are designed for industrial use and for loads & operational duty as stated in the catalogue. For further information please contact our sales department. Our deliveries are subject to the General Terms of Sale and Delivery according to our catalogue.

Lifting Speed

Normal version N: 1 mm stroke per movement of drive shaft (MSZ-150 and bigger sizes - higher speed acc. to table) at 1500 min⁻¹:
 → 1.5 m/min

Slow version L: 0.25 mm stroke per movement of drive shaft (MSZ-150 and bigger sizes - higher speed acc. to table) at 1500 min⁻¹:
 → 0.375 m/min

In order to increase the speed of the system the following options can be considered:

- Double pitch screw (Attention: max. input torque, system is not self-locking, system brake required)
- Larger diameter spindle with R version (spindle of the next larger size): depending on the screw jack size faster pitch, higher torque requirement
- Ball screw: various pitch options
- Rotary pulse encoder: Enables an increase in motor speed of more than 1500. This system is only designed for light loads and low duty operation.

To reduce system speed

- Use a motor with more poles / lower speed (6, 8, 10 or 12 poles)
- Rotary pulse encoder (for slower speed operation below 25 Hz an adequate method of cooling the motor is required)
- Geared motor (Attention to max input torque is required)
- Bevel gearbox with gear reduction (only for certain applications)

Temperature and Operating time

Screw jacks are generally not designed for continuous operation. Max operational time is stated as ED. These values are for reference only and must be checked against the individual application criteria. In borderline cases the next biggest gearbox may require selection or contact our technical dept. Operating temperatures should not exceed 80 degrees celsius.

Parallelism and Angularity

Care must be exercised to ensure that the systems are parallel to each other as well as level and aligned with the mounting surfaces. Connecting shafts, pillow blocks etc. must be axially aligned with each other.

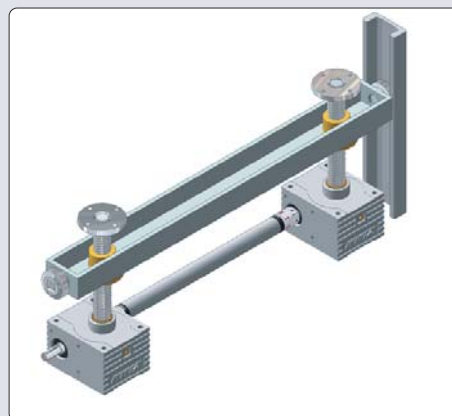

Guidance

The guide bushes incorporated in the screw jack gearbox can only tolerate a play of between 0.2 & 0.6 mm are not designed to take high side forces on the system. For most applications a suitable additional guidance system should be designed into the application to counteract any side forces.



Protection Against Rotation

With the standing screw version S the spindle is free running within the gearbox (worm wheel). It is therefore necessary to protect the spindle from rotating due to the friction in the worm wheel. This can be achieved by incorporating an additional external guidance system or by using the protection against rotation (mounted internally within the protective tube).

Construction Advice

Design & Specification

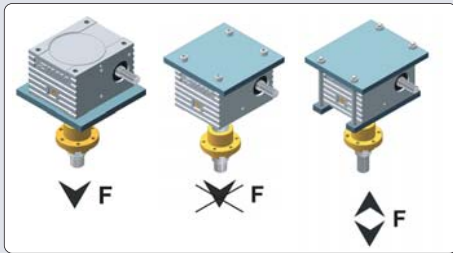

A flat-machined surface is necessary. The four attachment bolts are designed for the rated static loads of the gearbox in tension and compression. Additional impact loads and vibration must be taken into account (Grey cast iron housing GG25). The length of the mounting screws must be observed. Tension loads on the mounting bolts should be avoided. With unknown factors like shock and vibration we recommend additional protection of the screw jack by using guide rails and threaded rods. This will ensure loads in tension and compression are secured.

Safety Distances

Safety distances must be observed between moving and stationary components otherwise there is the risk of damage to the system.

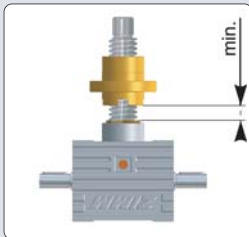

Accuracy

The repeat accuracy of the gearbox can be up to 0.05 mm if the load is constant and in the same direction. This requires also suitable control of the drive system e.g. using a rotary voltage braked motor in connection with a frequency converter, a rotary pulse encoder or a servo motor with encoder, etc.

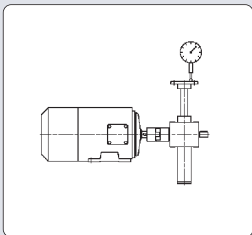

The pitch precision of the trapezoid screw is 0.2 mm per 300 mm of spindle length. With ballscrews it is 0.05 mm per 300 mm of spindle length.

Under alternating load, tension & compression the axial play can be up to 0.4 mm with the trapezoid spindle and 0.08 mm with the ballscrew.

Direction of Rotation and Movement

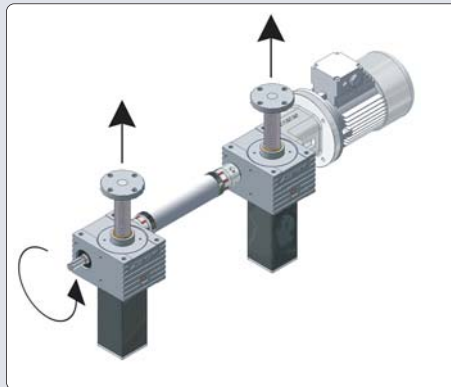

Check the direction of the required rotation and detail this in your design drawing or select one of the standard system layouts. With T bevel gearbox the direction of rotation can be changed by rotating the gearbox around.

Self-locking / Overrun

Screw jacks with a single pitch trapezoid thread have a limited self-locking capability. Where shock or vibration is evident a brake should be incorporated into the system.

The potential overrun after having stopped the motor differs from application to application. In order to minimise the overrun to a minimum we recommend to use a brake motor or a spring pressure brake FDB. A braked motor is essential where a double pitch trapezoid screw or ballscrew is used as they are not self locking.

Drive

In order to achieve soft start for acceleration and deceleration we recommend the use of a frequency inverter. The lifetime of the system will be increased and the noise of the system will be reduced.

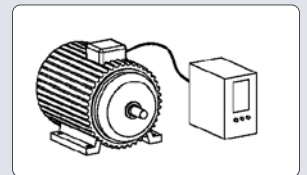

Trial Run

A trial run under normal operating condition including load is necessary to ensure correct operation. On-site trial runs are necessary to ensure precise alignment of the system and make any necessary adjustments.

Spare Parts

It is recommended that a range of spare parts gearboxes, spindles etc. are held by your customer. This is especially relevant where high duty application are involved.

Stage Engineering

ZIMM systems are specified to meet the regulation of the Stage Lifting industry.

Vehicles for Land, Air or Water

For applications, which are mobile either on land, sea or air are generally excluded from our normal warranty terms. Special conditions will apply. Please contact our sales department.

Environmental Conditions

For special applications outside of normal environmental conditions please contact our technical department.

CAD files

You can download the latest data from our homepage to support your design project:
www.zimm.at

Construction Advice

Lubrication

Sufficient lubrication is essential for the lifetime of the system. The spindle, gearbox & protection against rotation must be suitably lubricated. The red lubrication strip for the protection against rotation can be mounted in optional positions to meet your requirements. Please also see the automatic lubrication system) and maintenance instructions.

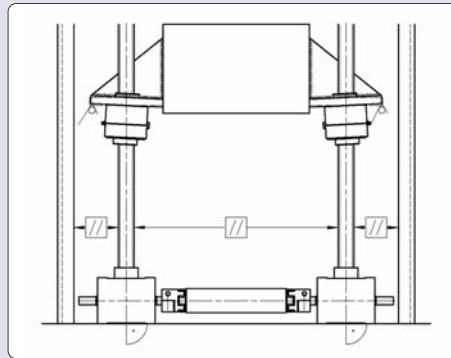

The mounting surfaces for the nuts should also be at right angles. The option of the self aligning nut should be considered for certain application.

Mounting, Operation and Maintenance Instruction

The installation instructions must be adhered to.

Construction Advice for Plant Engineers:

Where machined surfaces are used few assembly problems should be encountered. However geometric errors can occur in welded frames despite accurate assembly and it is therefore important to consider the following:

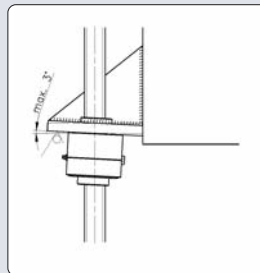

Parallelism / Angularity:

Screws and linear guides must be parallel otherwise the whole system could seize up during operation. All mounting surfaces for the gearboxes must be at right angles to the linear guides otherwise wear or damage to the components could occur.

Alternatively the use of the hinged bearing plate KAR could be considered.

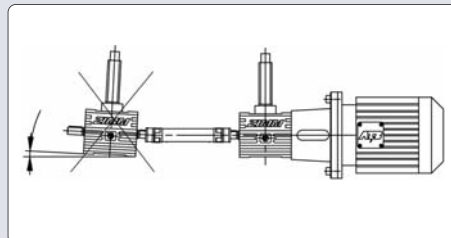

Printing errors, mistakes regarding dimensions, etc., as well as technical changes and improvements are excepted. Valid are the drawings which are have been checked and approved by both partners in accordance with the order acknowledgement.

With an application sketch and the completed checklist it will enable us to submit our quotation more speedily.

Checklist - Page 1 - Parameters

Company: _____ Date _____
 Address: _____ Phone.: _____
 Contact: _____ Fax: _____
 Departement: _____ Number of pages: _____

1 Axial capacity in kN, max.

- per gearbox kN per system kN
- in tension kN in compression kN
- load: static kN dynamic kN
- installation position: vertical horizontal
- idle impact load vibration

2 Lift / Travel mm

3 Lifting speed

- Type N = 1.5 m/min. Type L = 0.375 m/min.
 (MSZ-150 and bigger: slightly different speeds)
- Customer's requirements m/min (many variants are possible)

4a Operating time, operating cycle

- lifts per day lifts per hour hours per day: 8 16 24
- % operating time (ED) related to a 10 min period,
 for permanent operating see checklist page 2 (4b).

5 Gear type: S standing spindle R rotating spindle

6 Standard arrangement no. Dimension X1 X2 X3 Y

see standard arrangements, checklist pages 5 and 6!

7 Accessories YES NO see checklist page 3 or 4!

- 8 Motor: AC motor brake motor _____ manual operation
- spring pressure brake incremental encoder linear measuring system limit switches (S version)

9 Application objective / Function description

Description:

Operating conditions: Dry Humid Dusty Chips _____
 Ambient operating temperature: min. °C max. °C

10 Quantity: piece prototype first

11 Date: Offer: Delivery:

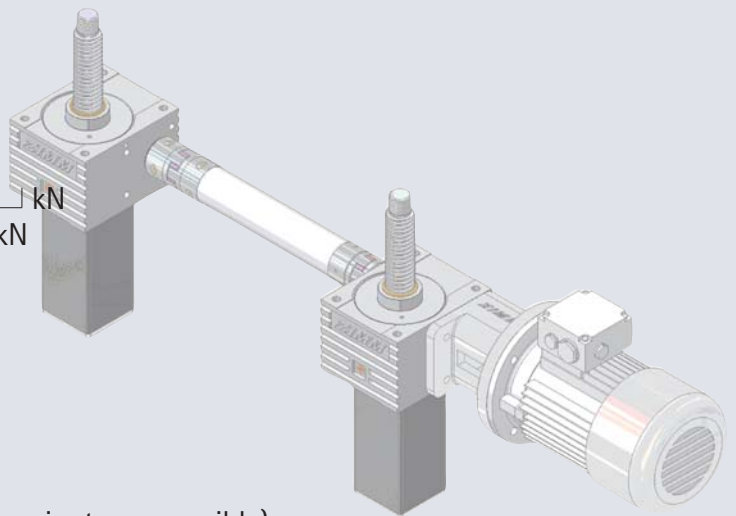

Checklist - Page 2 - Operating Times

Only required for extended operating times and high duty cycles.

- 4b Operating cycle for permanent operations / operation times
 Diagrams with times in seconds or minutes,
 resulting operating period in percent %, with calculation
 8 16 or 24 hours - operation / day

Example:

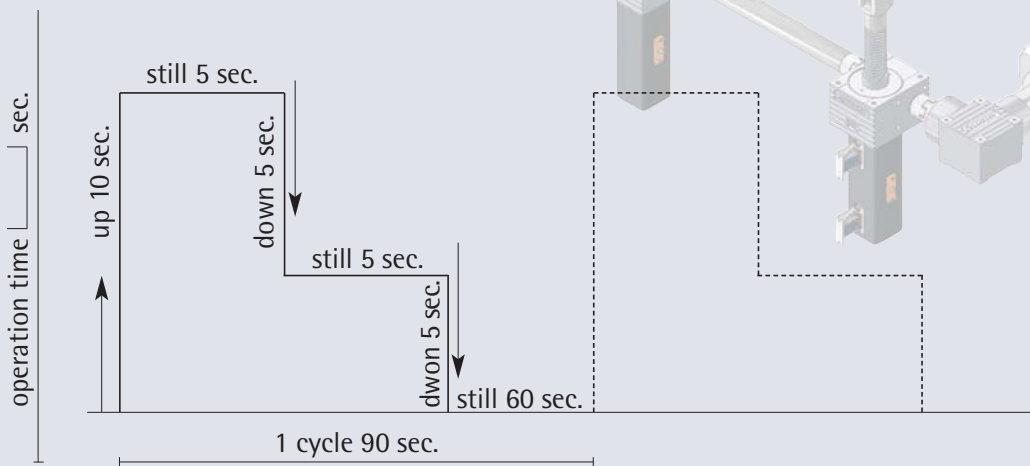

Idle time in sec. min. hours

Formula for calculating the relative operating period ED:

$$ED = \frac{te}{\sum(te+tp)} \times 100 \quad ED \text{ in } \%$$

ED = operating period
 te = operating time (in sec.)
 tp = idle time (in sec.)

$$ED = \frac{10 \text{ sec.} + 5 \text{ sec.} + 5 \text{ sec.}}{\sum(10 \text{ sec.} + 5 \text{ sec.} + 5 \text{ sec.} + 5 \text{ sec.} + 5 \text{ sec.} + 60 \text{ sec.})} \times 100 = 22,2\% \text{ per hour}$$

when operated 8hr/day

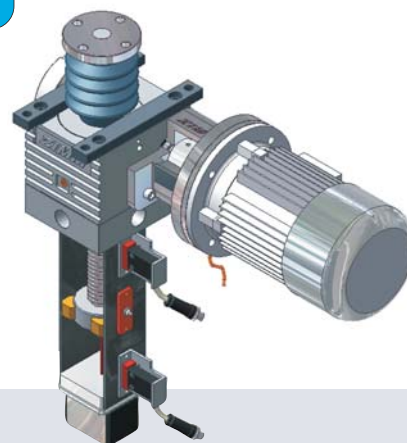
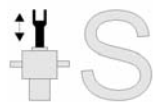

Checklist - Page 3 - Accessories S

Execution:

- SN (standing spindle, normal speed)
- SL (standing spindle, low speed)

base line ± 0,00

- Tension load [kn] statically
- Tension load [kn] dynamically
- Compression load [kn] statically
- Compression load [kn] dynamically
- Pivot bearing head
- Forked head
- Rod end
- Fixing flange
- Bellows
- Spiral spring
- Handwheel
- Motor with brake
- Motor without brake
- Coupling
- Rotary pulse encoder
- Mounting bars
- Motor flange
- Safety nut
- Hinged bearing plate
- Limit switch
- Spring pressure brake
- Protective cap
- Lubrication strip
- Protection against rotation
- Escape Protection
- Protective tube
- Linear measuring system

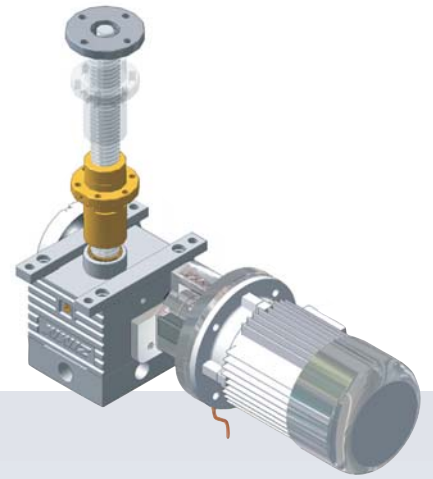
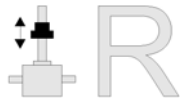

Checklist - Page 4 - Accessories R

Execution:

- RN (rotating spindle, normal speed)
- RL (rotating spindle, low speed)



Tension load [kn] dynamically

Compression load [kn] statically

Compression load [kn] dynamically

Opposed bearing plate

Bellows

Flat spiral spring covering

on top

on bottom

Duplex nut DM-1

Flange nut FM (trapezoid)

Flange nut KGT-F

Self-aligning nut PM-1

Greaseless nut FFDM

Driving flange TRMFL

Safety nut

Wear control

Mounting bars

Coupling

Tension Compression

Handwheel

Motor

Motor with brake

Rotary pulse encoder

Motor flange

Hinged bearing plate

Spring pressure brake

Protective cap

base line $\pm 0,00$

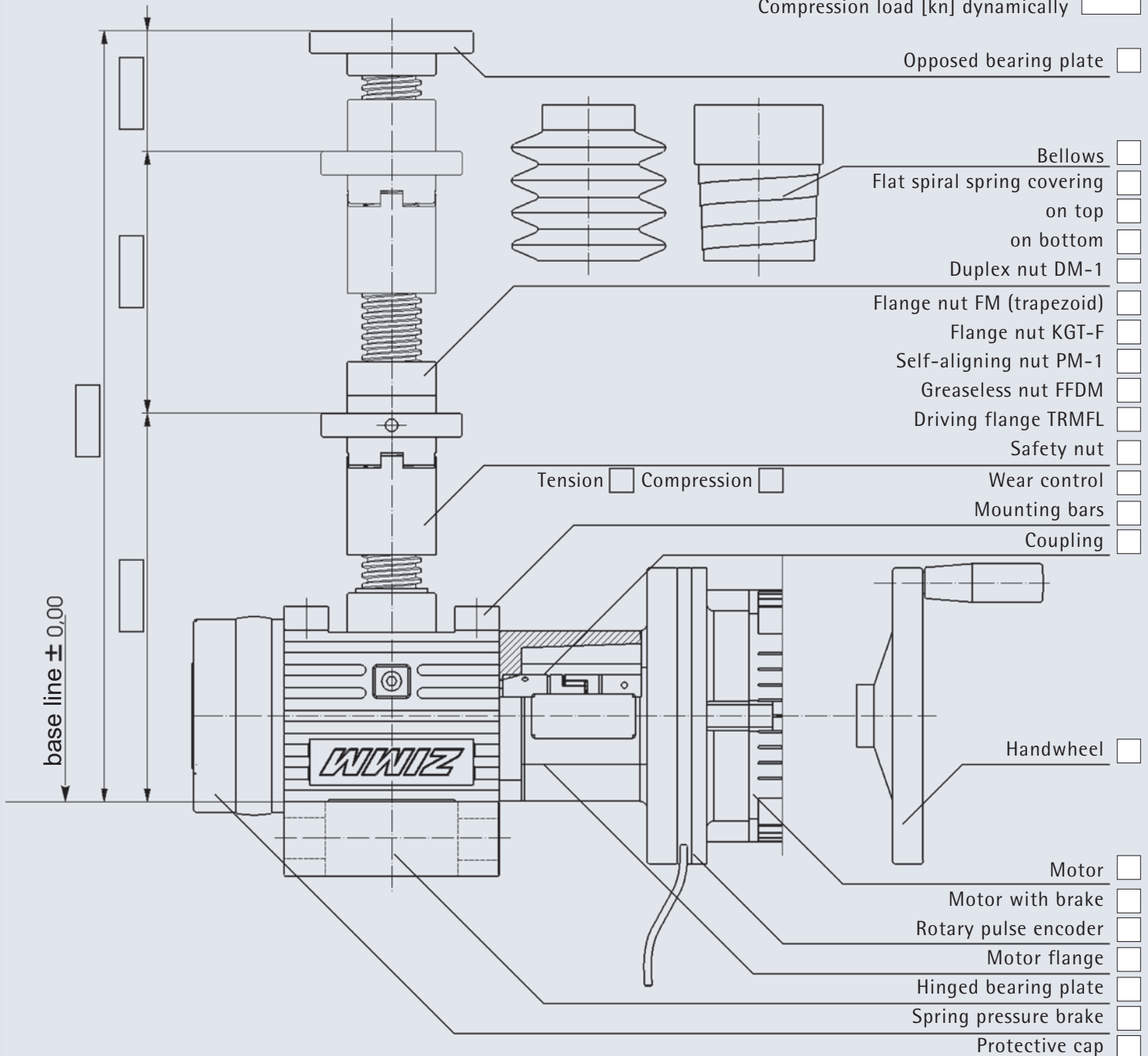

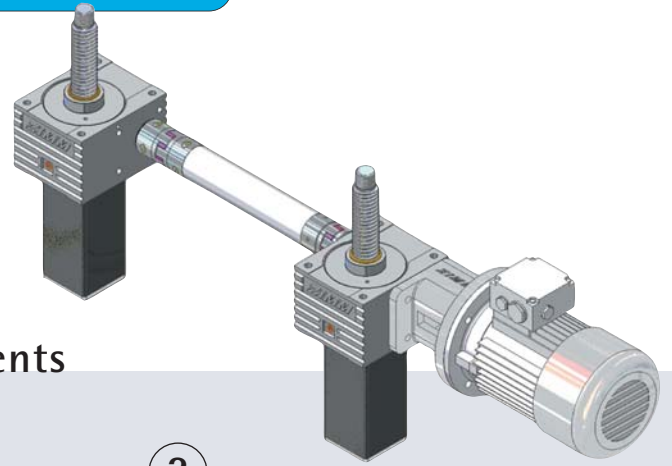

Checklist - Page 5 - Standard Arrangements

1

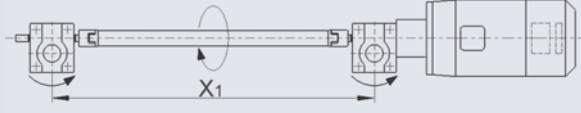

2

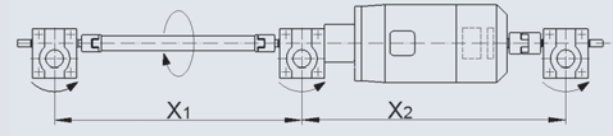

3

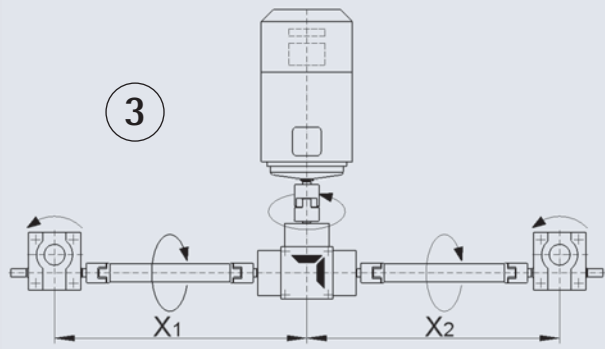

4

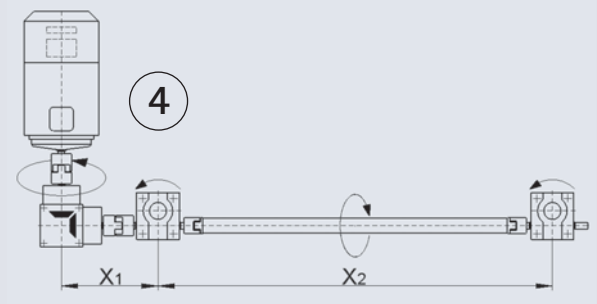

5

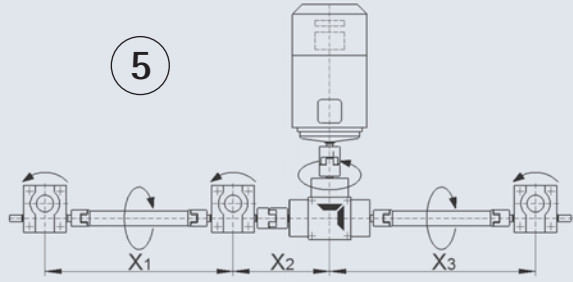

6

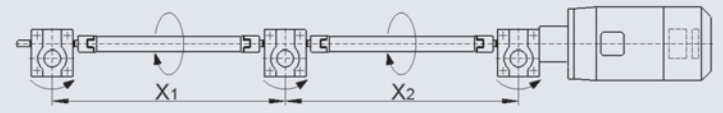

7

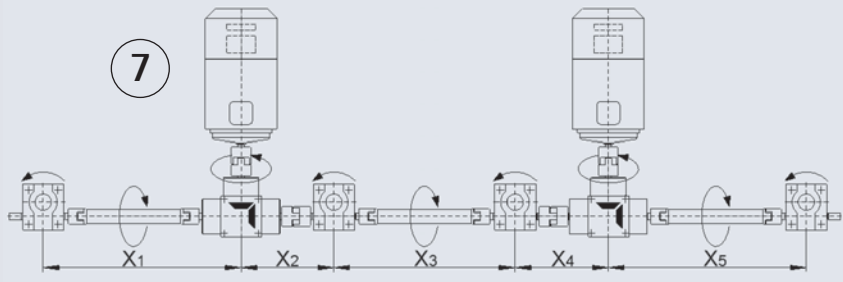

8

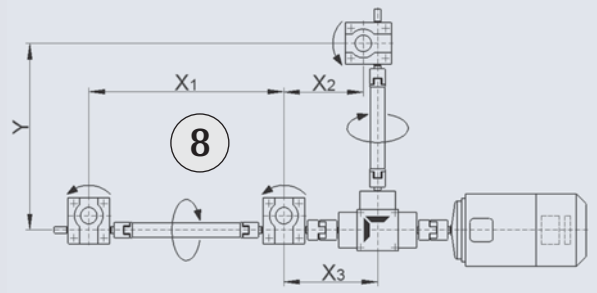

9

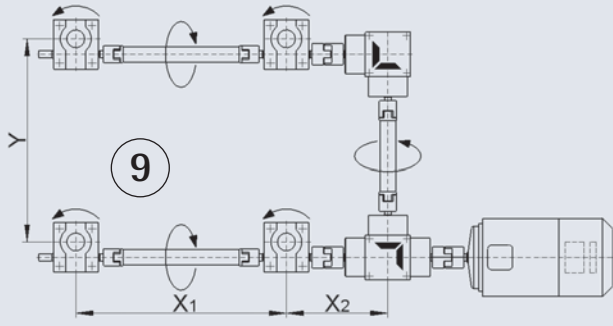

10

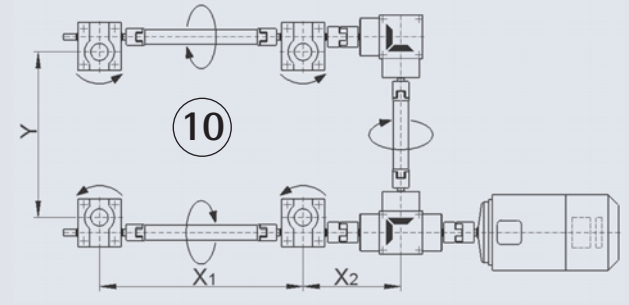

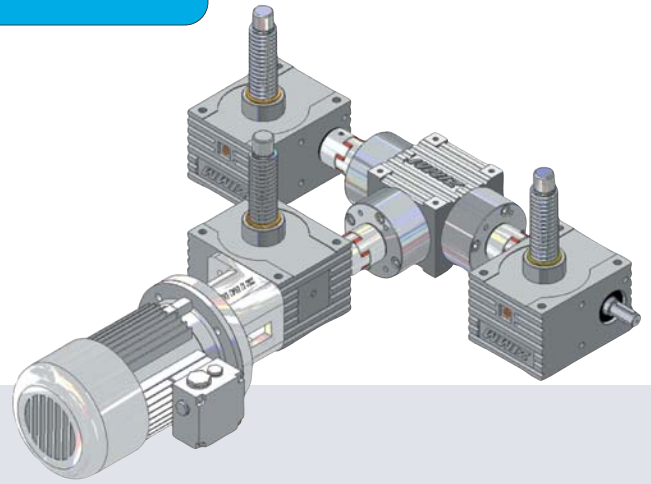

Checklist - Page 6 -
Standard Arrangements

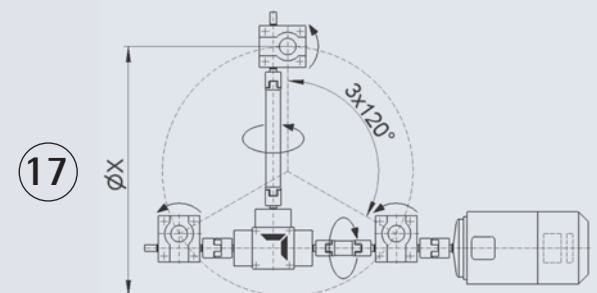
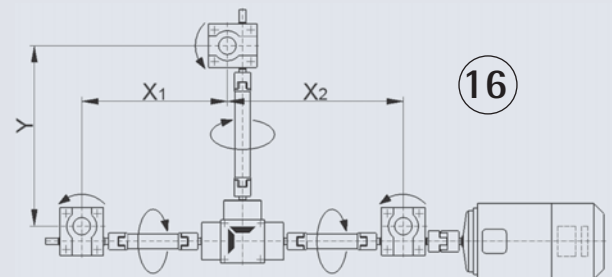
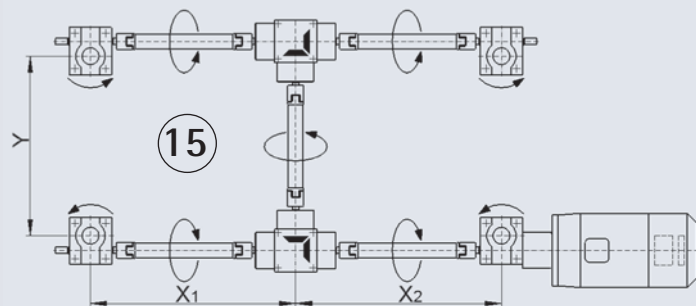
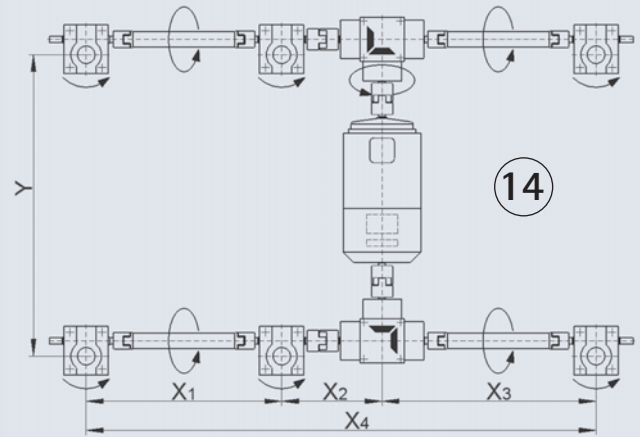
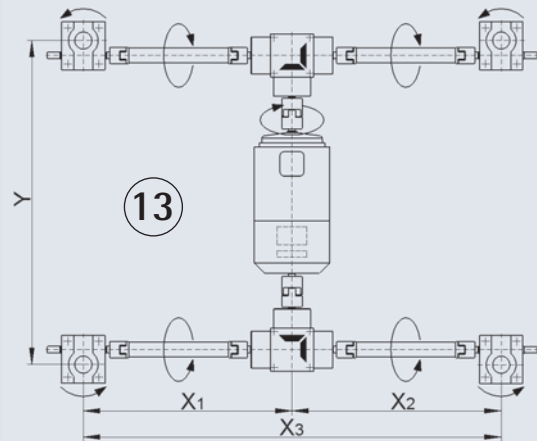
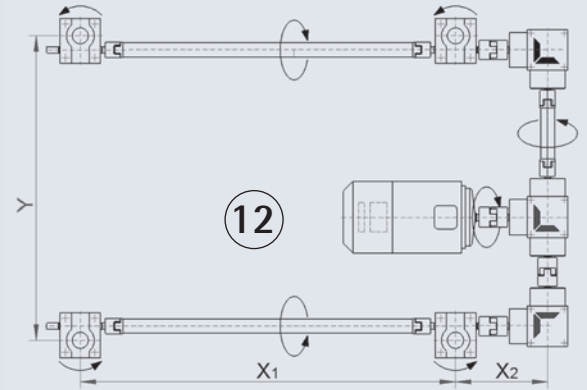
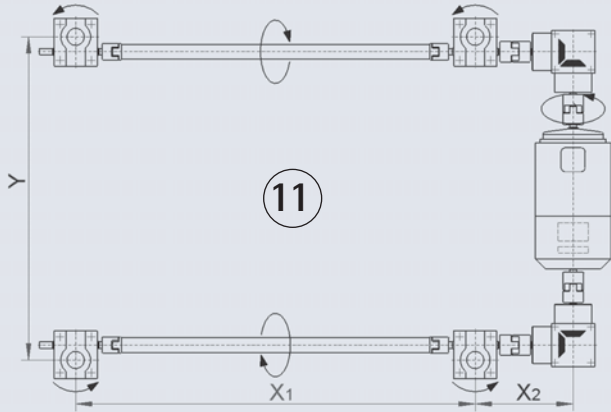

Critical Buckling Force of the Lifting Screw

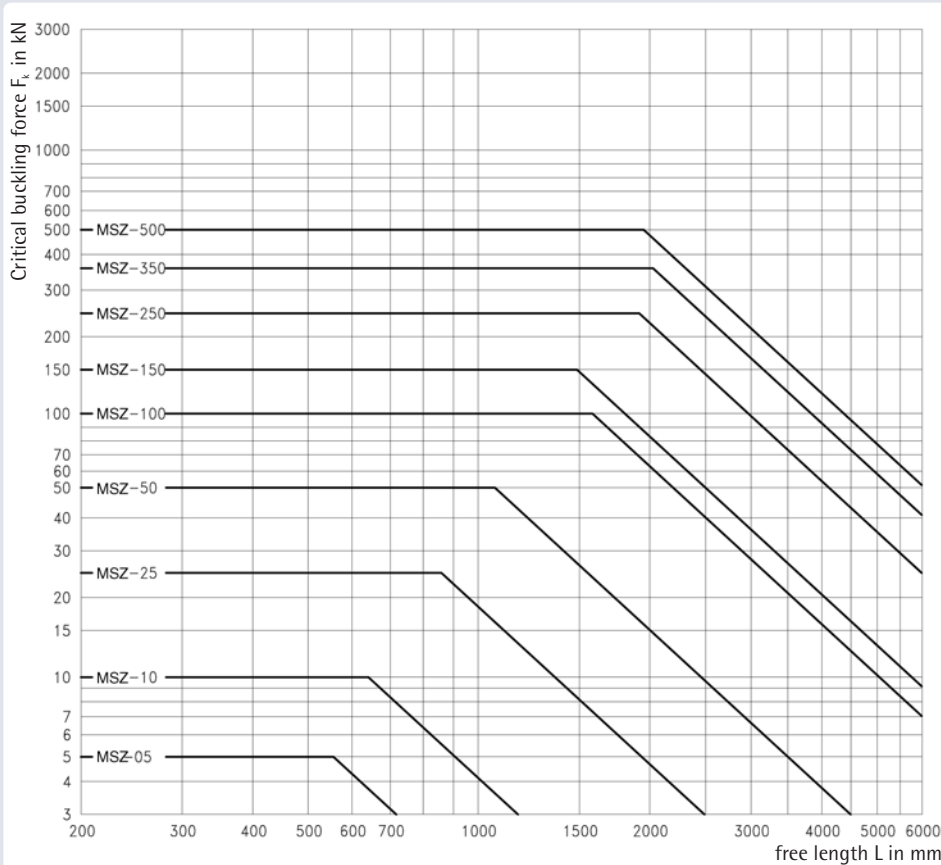
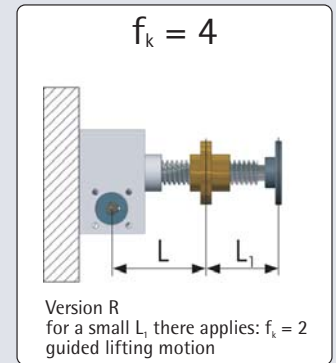
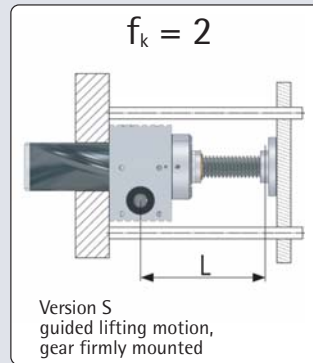
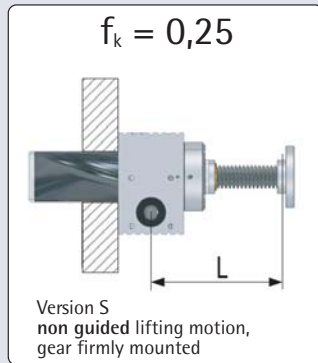
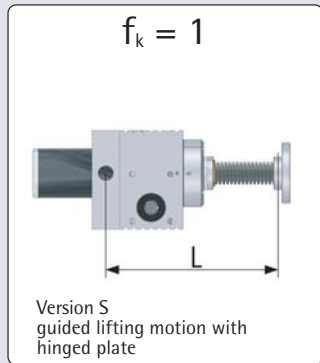

There is a buckling risk especially with gearboxes with long, thin spindles in combination with compression load. With the following calculation you can find the max. allowed axial load acc. to Euler.

Maximum allowed axial load

$$F_{all} = 0,8 \times F_k \times f_k$$

F_{all} maximum allowable axial load (kN)
 F_k theoretical critical buckling force (kN) acc. to diagram
 f_k correction value (considers kind of bearing support, respectively guidance of lifting load) see pictograms above

If the max calculated load is lower than required a larger spindle diameter could be selected. The calculations must then be reworked.
 With the rotating screw version a larger diameter screw can be selected (from the next bigger gearbox size).
 Any increase in pitch/ lifting speed must

be taken into account.

The safety factors for the type of system specified must be used, as shown above, to calculate the max allowable axial load for the system.

Critical Whirling Speed of Spindle - R Version

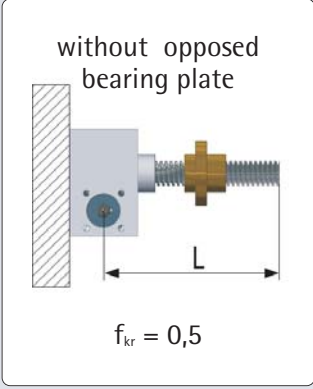
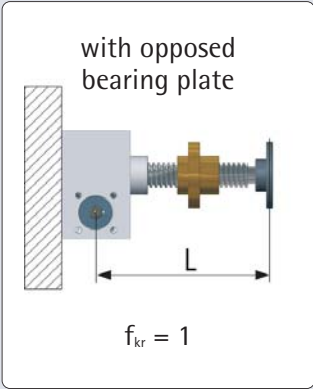
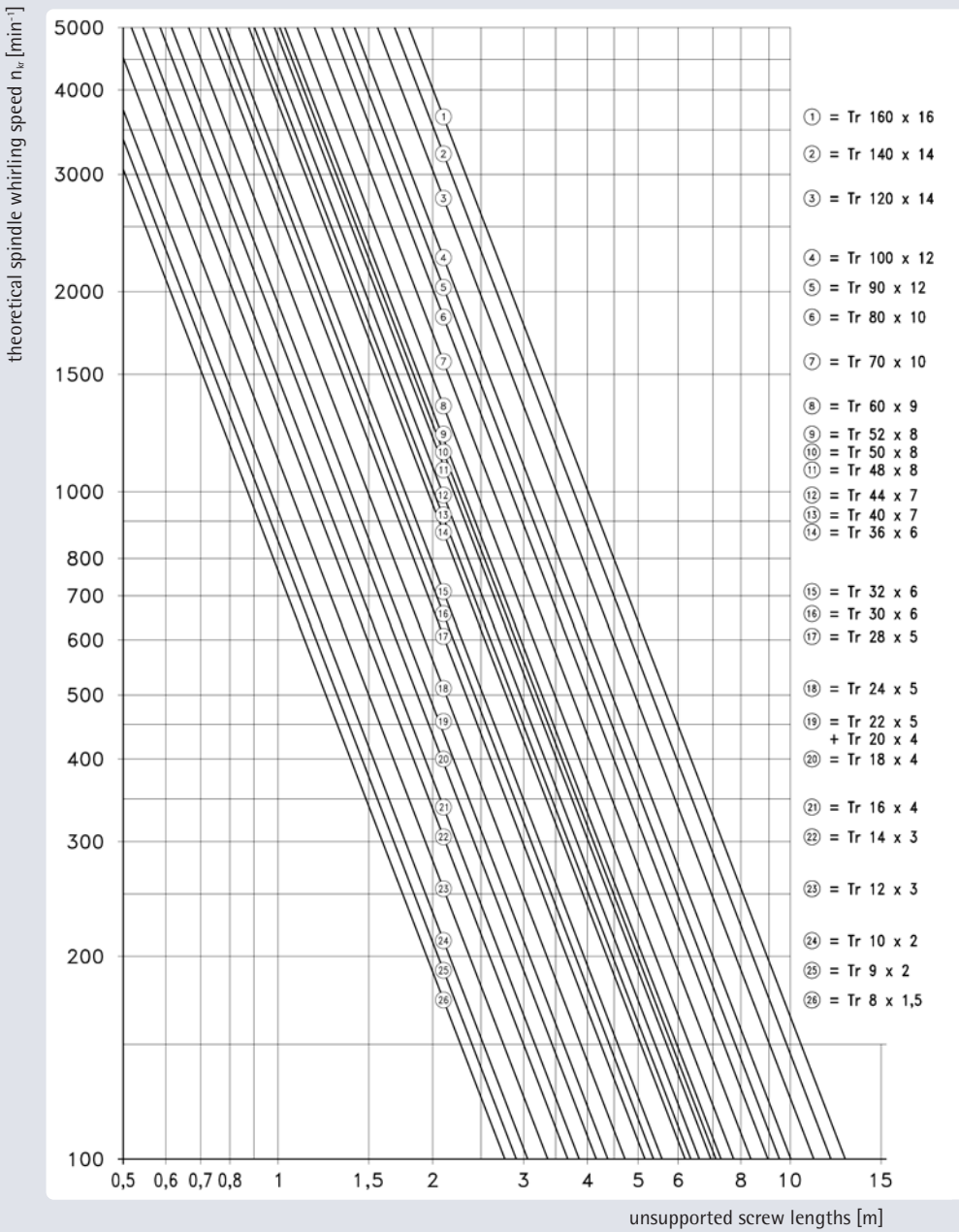

Maximum allowable spindle speed
 $n_{all} = 0,8 \times n_{kr} \times f_{kr}$

spindle speed = $\frac{\text{input speed}}{i_{gearbox}}$

For R version gearboxes (with rotating spindle) with long, thin spindles it is necessary to calculate the max. allowable spindle speed. Please take the theoretical critical speed n_{kr} from the diagram. Also consider the additional lengths for spindle covers, etc. when calculating the unsupported screw lengths. Together with the correction factor for the bearing layout the max. allowable

spindle speed can be calculated. If the calculated max spindle speed is lower than that required, a larger spindle should be selected. The calculations must then be reworked. If a larger diameter spindle is used in the R version the potential for higher drive torque's must be considered.

The safety factors for the type of system specified must be used, as shown above, to calculate the max allowable axial load for the system.

Determining the Drive Torque [M_G] of a Lifting Gear

With the formula shown below it is possible to calculate the necessary drive torque.
In order to facilitate the calculation of the drive torque we have determined multiplication factors out of this formula and have stated them in the technical data for the single gearbox version.

- M_G Required drive torque [Nm] of a lifting gear
- F Lifting load (dynamic) [kN]
- η_{Gearbox} Efficiency of the lifting gear (without spindle)
- η_{Spindle} Efficiency of the spindle
- P Spindle pitch [mm]
- i Transmission of the lifting gear
- M_L Idling torque [Nm]
- P_M Power of motor

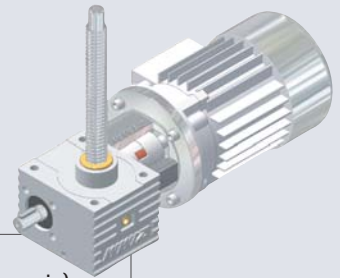

Formula¹⁾:

$$\text{Drive torque: } M_G = \frac{F \text{ [kN]} \cdot P \text{ [mm]}}{2 \cdot \pi \cdot \eta_{\text{Gearbox}} \cdot \eta_{\text{Spindle}} \cdot i} + M_L \text{ [Nm]}$$

$$\text{Power of motor: } P_M \text{ [kW]} = \frac{M_G \text{ [Nm]} \cdot n \text{ [min}^{-1}\text{]}}{9550}$$

Safety factor (start torque) = calculated drive torque x 1.3 to 1.5 (for smaller systems use up to x 2). **!**

Example:

MSZ-25-SN
 F = 12 kN (lifting load dynamic)
 η_{Gearbox} = 0,87 η_{Spindle} = 0,375
 P = 6 i = 6

$$M_G = \frac{12 \text{ kN} \cdot 6 \text{ mm}}{2 \cdot \pi \cdot 0,87 \cdot 0,375 \cdot 6} + 0,36 \text{ Nm} = \underline{6,21 \text{ Nm}}$$

$$P_M = \frac{6,21 \text{ Nm} \cdot 1500 \text{ min}^{-1}}{9550} = \underline{0,975 \text{ kW}}$$

Example: 0,975 kW · 1,4 = 1,365 kW → motor 1,5 kW

¹⁾ For gearboxes with one-pitch trapezoidal spindles it is also possible to multiply the factor which is stated on the corresponding gearbox page with the load.

Tr spindle η _{Spindle} Efficiency single pitch			Tr spindle η _{Spindle} Efficiency double pitch		
Tr	P	η lubricated	Tr	P	η lubricated
12	3	0,427	12	6	0,592
18	4	0,399	18	8	0,565
20	4	0,375	20	8	0,540
30	6	0,375	30	12	0,540
40	7	0,344	40	14	0,509
50	8	0,314	50	16	0,474
60	12	0,368	60	24	0,532
80	16	0,368	80	32	0,532
100	16	0,314	100	32	0,474
120	16	0,273	120	32	0,426
140	20	0,288	140	40	0,444

The efficiency of a trapezoid screw is substantially lower than that of ball screws due to friction. However, the trapezoid screw is technically more simple and more favourable. A safety device (e.g. a brake) is rarely required for trapezoid screws due to their self-locking capability. With a ballscrew system an efficiency factor of η=0,9 can be used. It is essential to incorporate a break into a ballscrew system.

Efficiency of gearboxes η_{Gearbox} (without spindle) at n = 1.500

	MSZ	2	5	10	25	50	100	150	250	350	500	650
N		0,82	0,84	0,86	0,87	0,89	0,85	0,84	0,86	0,87	0,84	0,85
L		0,77	0,62	0,69	0,69	0,74	0,65	0,67	0,72	0,70	0,62	0,65

Idling torques M_L of gearboxes [Nm]

	MSZ	2	5	10	25	50	100	150	250	350	500	650
N		0,06	0,10	0,26	0,36	0,76	1,68	1,90	2,64	3,24	3,96	5,60
L		0,04	0,08	0,16	0,26	0,54	1,02	1,20	1,94	2,20	2,84	3,40

With ball screws you basically can calculate with an efficiency factor of η=0,9.

Drive Torque for Gearboxes

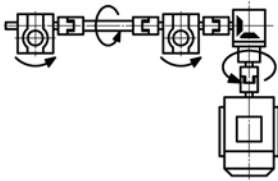

$$M_R = M_G \times 2,25$$

Calculation

The required drive torque of a lifting gear results from the sum of the moments of the individual lifting units. This is increased due to frictional losses of transmission components like couplings, connecting shafts, bevel gears, etc.

To simplify the calculation, some factors for determining the drive torque in the most common applications are provided below.



$$M_R = M_G \times 2,1$$

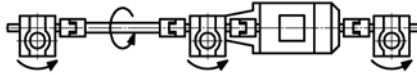

$$M_R = M_G \times 3,1$$

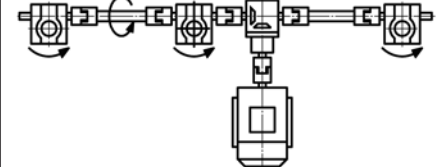

$$M_R = M_G \times 3,35$$

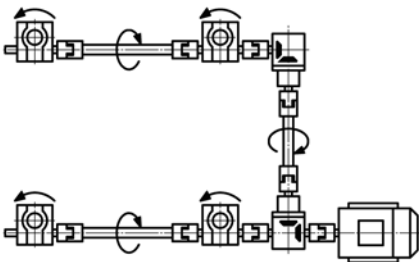

$$M_R = M_G \times 4,6$$

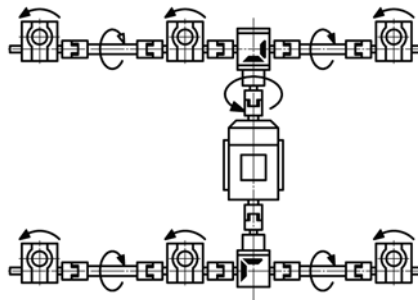

$$M_R = M_G \times 6,8$$

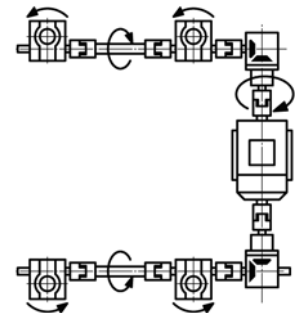

$$M_R = M_G \times 4,4$$

M_R - Total drive torque for the whole system

M_G - Input torque of a single gearbox

M_A - Starting torque max. $1,5 \times M_R$

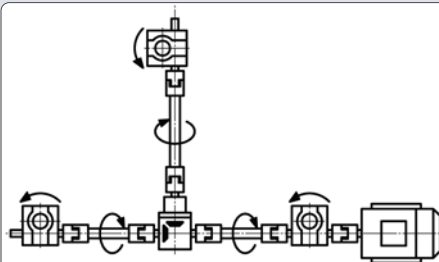

$$M_R = M_G \times 3,34$$

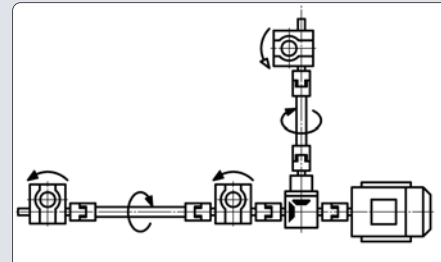

$$M_R = M_G \times 3,27$$

Example (example from the left page, 12 kN per gearbox)

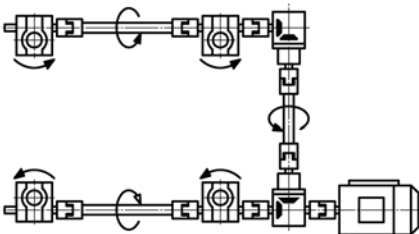

$$M_R = M_G \times 4,6 = 6,21 \text{ Nm} \times 4,6 = \underline{28,57 \text{ Nm}}$$

→ x safety factor 1,3 = 37,14 Nm

Attention:

It is recommended to multiply the calculated value with a safety factor of 1.3 to 1.5 (for smaller systems factor up to 2). The indicated values are applicable in cases of uniform distribution of the lifting gear load onto all gears!

Maximum Power / Moments

Load definitions

- F - Lifting load tension and/or compression
- F_S - Side forces on the spindle
- v_H - Lifting speed of the spindle
(or nut of the R version)
- F_A - Axial load of the input shaft
- F_R - Radial load of the input shaft
- M_R - Drive torque
- n_R - Drive speed

Please examine the information on the following pages before making your choice of the lifting gear suited for your application. Various influences and assumptions can only be estimated on the basis of information gained by experience. In case of doubt please contact our sales engineers.

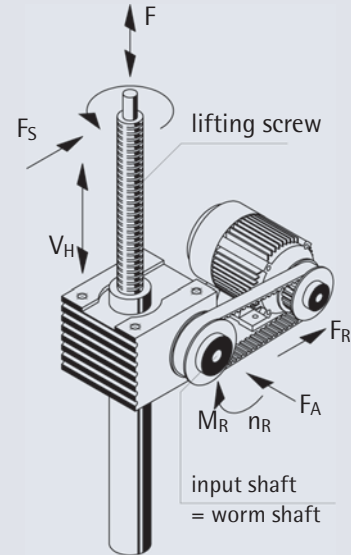

Side forces on the spindle

Please refer to the adjoining table for the maximum permissible side force. Side forces should be supported by a guidance system whenever possible. The bronze bushings in the gearbox are a secondary support only and should not be relied upon as adequate guidance. The maximum side force at a given screw extension must not exceed that stated in the adjoining table. Attention: only statically allowed!

maximum side force F_S [N] (static)

extended screw length in mm

MSZ	100	200	300	400	500	600	700	800	900	1000	1200	1500	2000	2500	3000
5	360	160	100	70	55	45	38	32	28	25	20	18	12	-	-
10	600	280	180	130	100	80	70	60	50	47	40	30	20	15	-
25	900	470	300	240	180	150	130	110	100	90	70	60	45	35	30
50	3000	2000	1300	900	700	600	500	420	380	330	280	230	160	130	100
100	5000	4000	3000	2300	1800	1500	1300	1100	950	850	700	600	400	350	250
150	5500	5000	3900	2800	2300	1800	1500	1300	1200	1000	850	750	500	400	350
250	9000	9000	6500	4900	3800	3000	2500	2200	2000	1900	1450	1250	900	760	660
350	15000	13000	12000	10000	8800	7000	6000	5500	4800	4300	3500	3000	2000	1600	1400
500	29000	29000	29000	29000	29000	24000	20000	17000	15000	14000	12000	9000	7000	5600	4900
650	34800	34800	34800	34800	34800	28800	24000	20400	18000	16800	14400	10800	8400	6720	5880
750	46000	46000	39000	36000	32000	30000	25000	29000	25000	23500	20000	17000	12000	10000	8000

Max. drive torque

The stated values of the table on the right should not be exceeded. If gearboxes are arranged in tandem or in larger arrangements the maximum drive torque may be higher. If there are more than 5 gearboxes in an arrangement please contact our sales engineers.

maximum drive torque M_R [Nm]

Type	min ⁻¹	SHZ-02	MSZ-5	MSZ-10	MSZ-25	MSZ-50	MSZ-100	MSZ-150	MSZ-250	MSZ-350	MSZ-500	MSZ-650	MSZ-750
M _R SN/RN	1500	0,7	6,4	12,6	21,7	44,7	72,0	67,3	118,4	187,0	204,3	268,3	415,0
M _R SN/RN	500	1,0	10,4	20,5	34,2	70,3	114,9	107,0	185,1	295,7	325,6	427,9	663,0
M _R SL/RL	1500	0,5	2,6	5,3	7,8	15,5	17,0	17,3	23,5	40,2	42,8	62,8	83,0
M _R SL/RL	500	0,7	4,3	8,4	12,5	24,5	27,8	27,7	36,6	63,9	71,2	102,6	132,0

- Consider that the starting torque is factor 1.5 of the operation torque
- Limit values are mechanical - consider thermal factors depending on operating time

Radial load on the input shaft

The radial forces of the table on the right should not be exceeded if you use chain drives or belt drives.

maximum radial load acting on the input shaft F_R [N]

	SHZ-02	MSZ-5	MSZ-10	MSZ-25	MSZ-50	MSZ-100	MSZ-150	MSZ-250	MSZ-350	MSZ-500	MSZ-650
F _R max.	18	110	215	300	520	800	810	1420	2100	3780	4536

Calculating Spindle and Protective Tube Lengths

The following tables will allow calculation of the required spindle and protective tube length for the screw jack system selected.

Basic

Depending on gearbox version and system components the spindle (and protective tube for S version) have to be extended.

These lengths are important. For non standard layouts please provide a drawing or contact the technical department.

Stroke + basic length (+ extensions for variants/system components)

Example S:

MSZ-25-SN, stroke: 250 mm
 bellow MSZ-25-FB-300 (compression ZD=70 mm)
 fixing flange BF (therefore bellow without retainer)
 protection against rotation VS
 limit switch ESSET

Spindle length Tr:

$$\begin{array}{rcccccc}
 250 & + & 180 & + & 43 & + & 44 & = & 517 \text{ mm} \\
 \text{stroke} & & \text{basic length} & & \text{bellow} & & \text{limit switch} & & \text{spindle length} \\
 & & & & (70-27=43) & & + \text{ protection against rotation} & &
 \end{array}$$

protective tube length SRO:

$$\begin{array}{rcccccc}
 250 & + & 55 & + & 71 & = & 376 \\
 \text{stroke} & & \text{basic length} & & \text{limit switch} & & \text{protective tube length} \\
 & & & & + \text{ protection against rotation} & &
 \end{array}$$

Example R:

MSZ-25-RN, stroke 250 mm
 spindle with pilot (opposed bearing plate GLP)
 bellow MSZ-25-FB-300 (compression ZD=70 mm) below and above
 duplex nut DM

Spindle length Tr:

$$\begin{array}{rcccccc}
 250 & + & 145 & + & 60 & + & 55 & + & 50 & = & 560 \text{ mm} \\
 \text{stroke} & & \text{basic length} & & \text{bellow gearbox-sided} & & \text{2. bellow} & & \text{duplex nut} & & \text{spindle length} \\
 & & & & (70-10=60) & & (70-15=55) & & & &
 \end{array}$$

Length calculation for connecting shafts can be found in catalogue 2006.

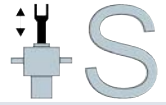

Length Calculation, Standing Version S - Spindle

spindle extension S version below gearbox (tube side)

	MSZ-5	MSZ-10	MSZ-25	MSZ-50	MSZ-100	MSZ-150	MSZ-250	MSZ-350	MSZ-500
Tr basic length	139	161	180	240	325	338	386	434	524
Tr basic length with safety nut	-	192	216	276	362	384	467	522	626
Tr basic length Anti-Backlash									
KGT basic length	16x05 203 16x10 223	25x05 238 25x10 258	32x05 263 32x10 273	40x05 326 40x10 326	50x10 430 50x20 470	63x10 427	-	-	-
		25x25 328 25x50 458	32x20 303 32x40 373	40x20 356 40x40 416			-	-	-
Escape prot./prot. against rot. (WMS)	15	20	20	30	30	30	30	35	40
Limit switch ₃ (+ linear measuring syst.)	41	45	44	55	55	48	48	53	58
ES ₃ and hinged bearing plate (WMS)	63	63	69	80	90	95	107	119	154

spindle extension S version above gearbox

	MSZ-05	MSZ-10	MSZ-25	MSZ-50	MSZ-100	MSZ-150	MSZ-250	MSZ-350	MSZ-500
Bellows with bushing (GK / KGK) ₁	ZD -2	ZD +1	ZD +5	ZD +10	ZD +8	ZD +2	ZD +2	ZD +2	ZD +2
Bellows without bushing (BF / SLK) ₁	ZD -22	ZD -24	ZD -27	ZD -36	ZD -40	ZD -18	ZD -18	ZD -18	ZD -18
Bellows and KAR with FBR (GK / KGK) ₁	ZD +32	ZD +34	ZD +53	ZD +67	ZD +81	ZD +71	ZD +93	ZD +114	ZD +136
Bellows and KAR without FBR (BF / SLK) ₁	ZD +12	ZD +9	ZD +22	ZD +21	ZD +33	ZD +51	ZD +73	ZD +94	ZD +116

ZD-Measures: see catalogue 2006

Safety distances are already included in basic lengths!

(Tr spindle: 10mm up to MSZ-100, 16mm from MSZ-150, for KGT see catalogue 2006, dimension L3)

- 1) The value will be added or subtracted to the ZD dimension of the bellow - the result will then be added to the spindle length.
(e.g. ZD = 70 >> "ZD-22" = 48 mm >> spindle extension for bellow is 48 mm)
- 2) Bellow, bellow ring and bellow adapter are similar to MSZ-500
- 3) Limit switches ES are always in combination with protection against rotation VS (VS is in the extension included)

Spindle extension for spiral spring covering SF:

As the extension of the spiral spring covering differs depending on the attachment,

this variant has to be calculated graphically.

If necessary we would be pleased to generate this drawing.

Abbreviations:

AS	Escape protection	KAR	Hinged bearing plate
BF	Fixing flange	KGK	Rod end
ES	Limit switch	SLK	Pivot bearing head
FBR	Bellows connecting ring	WMS	Linear measuring system
GK	Forked head	ZD	Compression

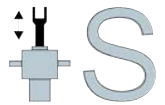
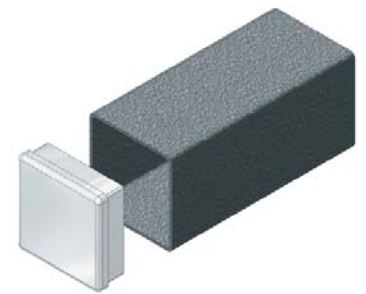

Length Calculation, Standing Version S – Protective Tube SRO

protective tube extension S version

	MSZ-5	MSZ-10	MSZ-25	MSZ-50	MSZ-100	MSZ-150	MSZ-250	MSZ-350	MSZ-500
Tr basic length ¹⁾	48	50	55	64	75	87	92	102	112
KGT basic length ¹⁾	16x05 60	25x05 60	32x05 65	40x05 74	50x10 95	63x10 95	-	-	-
	16x10 80	25x10 80	32x10 75	40x10 74	50x20 135		-	-	-
		25x25 150	32x20 105	40x20 104			-	-	-
		25x50 280	32x40 175	40x40 164			-	-	-
Escape prot./prot. ag. rotat. AS/VS	15	20	20	30	30	30	30	35	40
Limit switch ES ₃ (+ WMS) + VS	69	72	71	82	82	69	69	74	79
ES ₃ and hinged bearing plate KAR	91	90	96	107	117	116	128	140	175
VS + Linear measuring system WMS	31	36	36	46	46	46	46	51	56

Attention: minimum stroke with limit switch ES:

min.stroke with limit switch ES ^{3) 2)}	48	46	47	37	37	37	37	32	27
min.stroke with ES ₃ + lubric. strip ²⁾	118	116	117	107	107	107	107	102	97

1) Basic length of protective tube without cap - to achieve the whole protective tube length add another 5 mm for the cap

2) Is a lower stroke required as stated above, the limit switches and the lubrication strips have to be mounted on two different sides (assembly position)!

3) Limit switches ES are always in combination with protection against rotation VS (VS is in the extension included)

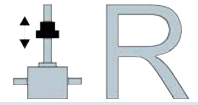

Length Calculation, Rotating Version R - Spindle

	MSZ-05	MSZ-10	MSZ-25	MSZ-50	MSZ-100	MSZ-150	MSZ-250	MSZ-350	MSZ-500
Tr basic length without machined end	93	106	120	163	212	251	279	311	352
Tr basic length with machined end (= standard for opposed bearing plate GLP)	108	126	145	193	257	306	354	411	472
Tr basic length larger diameter with machined end ¹⁾	113	131	150	208	267	326	379	431	472
KGT basic length without machined end ²⁾ (including nut)	16x05 145	25x05 158	32x05 185	40x05 230	50x10 327	63x10 379	80x10 407		
	16x10 178	25x10 191	32x10 209	40x10 244	50x20 367	63x20 449	80x20 ³⁾ 487		
		25x25 241	32x20 250	40x20 283			80x20 ⁴⁾ 502		
		25x50 394	32x40 285	40x40 348					
KGT basic length larger diameter without machined end ²⁾ (including nut)	25x05 145	32x05 171	40x05 187	50x10 278	63x10 352	80x10 379			
	25x10 178	32x10 195	40x10 201	50x20 318	63x20 422	80x20 ³⁾ 459			
	25x25 228	32x20 236	40x20 240			80x20 ⁴⁾ 474			
	25x50 381	32x40 271	40x40 305						
KGT basic length with machined end ²⁾ (including nut)	16x05 160	25x05 178	32x05 210	40x05 260	50x10 372	63x10 434	80x10 482		
	16x10 193	25x10 211	32x10 234	40x10 274	50x20 412	63x20 504	80x20 ³⁾ 562		
		25x25 261	32x20 275	40x20 313			80x20 ⁴⁾ 577		
		25x50 414	32x40 310	40x40 378					
KGT basic length larger diameter without machined end ²⁾ (including nut)	25x05 165	32x05 196	40x05 217	50x10 323	63x10 407	80x10 454			
	25x10 198	32x10 220	40x10 231	50x20 363	63x20 477	80x20 ³⁾ 534			
	25x25 248	32x20 261	40x20 270			80x20 ⁴⁾ 549			
	25x50 401	32x40 296	40x40 335						
Flange nut FM	35	44	46	66	75				
Duplex nut DM	45	45	50	70	90	115	140	160	180
Self-aligning nut PM	78	83	95	129	190	210	224	-	-
Greaseless nut FFDM	53	53	59	85	-	-	-	-	-
DM + Safety nut SIFA	70	84	95	133	173	211	249	266	303
PM + Safety nut SIFA	123	128	158	212	300	330	374	-	-
1. FB gearbox-nut ⁵⁾	ZD -12	ZD -12	ZD -10	ZD -12	ZD -12	ZD -18	ZD -18	ZD -18	ZD -18
2. FB nut-opposite bearing plate ⁵⁾	ZD -10	ZD -14	ZD -15	ZD -15	ZD -10	ZD -26	ZD -36	ZD -56	ZD -21
KAR ⁶⁾ spindle-sided and 1. bellow ⁵⁾	ZD +18	ZD +18	ZD +32	ZD +32	ZD +46	ZD +42	ZD +65	ZD +80	ZD +100

Safety distances are already included in basic lengths!

(Tr spindle: 10 mm up to MSZ-100, 16 mm from MSZ-150, for KGT see catalogue 2006, dimension L3)

- 1) When using a larger diameter spindle also select the system components of the next bigger gearbox.
(MSZ-10 with larger diameter spindle has spindle Tr30x6, system components of MSZ-25 - therefore also calculational spindle extension of gearbox size 25).
- 2) The basic length of KGT spindles includes the length of the KGT nut and the safety distance according to ZIMM catalogue (see catalogue 2006, size L₃).
- 3) KGT nut with dynamic load rating 135kN and static load rating 322kN (80x20-4EP).
- 4) KGT nut with dynamic load 161,5kN and static load rating 398kN (80x20-5EP).
- 5) The value will be - depending on the algebraic sign - added or subtracted of the ZD (compression) dimension of the bellow - the result will then be added to the spindle length.
- 6) KAR is the hinged bearing plate

Spindle extension for spiral spring covering SF:

As the extension of the spiral spring covering differs depending on the attachment, this variant has to be calculated graphically.
If necessary we would be pleased to generate this drawing.

Order - Code MSZ

